

## THREE PHASE POWER/ENERGY METERING MODULE FOR SPI BUS AND PULSE OUTPUT DEVICES

### FEATURES

- Module used for both SA9604A and SA9605A evaluation
  - Meets the accuracy requirements for Class 1 AC Watt hour meters
  - Operates over a wide temperature range
- Uses current transformers for current sensing
  - Protection against ESD
  - Unused connection pads allows the module to be customised

### DESCRIPTION

This innovative power/energy module allows evaluation of both the SA9604A and SA9605A, members of the SAMES three phase metering I.C. family.

It is advised that the relevant data sheet for the device under evaluation be read in conjunction with this Application Note.

The output of this innovative universal three phase power/energy metering circuit is ideally suited for energy calculations in applications using a  $\mu$ -controller (SA9604A and SA9605A) or mechanical counter (SA9605A).

On the left hand side of the board, next to the 25-way D-type connector, the array of unused solder pads allow the user to customise the module. This section of the board may be used to access the opto-coupler isolated output signals. Such components as counters and LEDs may be added to this area to allow the user evaluation of a design using the SA9604A or SA9605A.

***CARE MUST BE TAKEN WHEN CONNECTING ADDITIONAL COMPONENTS TO THE BOARD AS DANGEROUS VOLTAGE LEVELS EXIST IN SOME AREAS.***

### BLOCK DIAGRAM

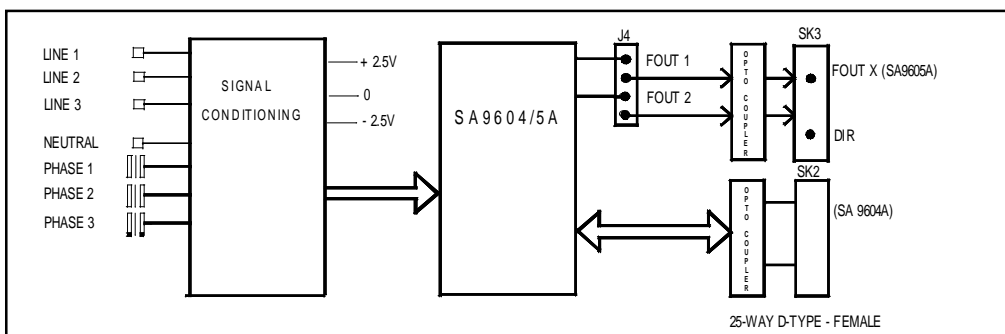

## PM9604/5AP

### ABSOLUTE MAXIMUM RATINGS\*

Parameter	Symbol	Min	Max	Unit
Supply Voltage (Note 1)	$V_{AC}$		540	V
Storage Temperature	$T_{STG}$	-25	+125	°C
Operating Temperature (Note2)	$T_O$	-10	+70	°C

Note 1: Voltages are specified with reference to Neutral.

Note 2: The SA9604A and SA9605A integrated circuits are specified to operate over the temperature range -10°C to +70°C. The module functionality will, however, depend upon the external components used.

\*Stresses above those listed under "Absolute Maximum Ratings" may cause permanent damage to the device. This is a stress rating only. Functional operation of the device at these or any other conditions above those indicated in the operational sections of this specification, is not implied. Exposure to Absolute Maximum Ratings for extended periods may affect device reliability.

### ELECTRICAL CHARACTERISTICS

(Over the temperature range -10°C to +70°C, unless otherwise specified. Power consumption figures are applicable to the PM9604/5APE only.)

Parameter	Symbol	Min	Typ	Max	Unit	Condition
Supply voltage (3 phase) (Continuous)	$V_{AC}$	180	230	265	V	PM9604/5APE
		90	115	138	V	PM9604/5APA
Output		Refer to applicable IC data sheet				
Power consumption <sup>1</sup>				2.4	W	$V_{DD} = 5V$

Note 1: Power consumption specifications exclude power consumed by the current sensor.



**CONNECTION DESCRIPTION**

<b>Designation</b>	<b>Description</b>
MAINS	Voltage supply connection to Phase 1
	Voltage supply connection to Phase 2
	Voltage supply connection to Phase 3
	Voltage supply connection to Neutral Live (common)
SK2 25-Way female (D-type)	P1 Supply (+ve) to opto-couplers
	P7 Input SA9604A - SCK
	P8 Input SA9604A - DI
	P9 Input SA9604A - CS
	P12 Output SA9604A - DO
	P18, 20 - 25 Common emitters and cathodes of opto-couplers
SK3 4-Way male	1. Supply (+ve) to opto-couplers
	2. Output SA9605A - FOUT1 / FOUT2 (selectable)
	3. Output SA9605A - DIR
	4. Common emitters and cathodes of opto-couplers

**SELECTION PINS**

<b>Jumper</b>	<b>Description</b>
JP1	CT1 selection
JP2	CT2 selection
JP3	CT3 selection
JP4	SA9604A - SCK signal connection SA9605A - FOUT1 on FOUT2 selection
JP5	SA9604A - DI signal connection SA9605A - PGM1 level selection
JP6	SA9604A - CS signal connection SA9605A - PGM0 level selection
JP7	Resistor selection for on-chip bias and reference current

## FUNCTIONAL DESCRIPTION

### 1. Power Calculation

In the Application Circuit (Figure 2), the output current from the current sensor will be between 0 and  $16\mu\text{A}_{\text{RMS}}$ . The current input stage saturates at input currents greater than  $18\mu\text{A}_{\text{RMS}}$ . The mains voltage (mains voltage + 15% -20%) is used for the power calculation, together with the current information from the current sensor (current transformers).

For rated conditions, the signals into the current and voltage sensor inputs are set as follows:

Current sensor input currents:  $16\mu\text{A}_{\text{RMS}}$

Voltage sensor input currents:  $14\mu\text{A}_{\text{RMS}}$

### 2. Electrostatic Discharge (ESD) Protection

The device's inputs/outputs are protected against ESD. The modules resistance to transients will be dependant upon the protection components used.

### 3. Power Consumption

The overall power consumption rating for this power metering application (Figure 2), is under 2.4W, excluding the current sensors.

### 4. Isolation

The reference for the unit is connected to neutral.

### 5. Isolated Input/Output Interface

The isolated interface is provided to allow the user to access the registers of the SA9604A and the output signals of the SA9605A.

Two connector types are available on the PM9604/5AP module to access the outputs of the two devices:

SK2 - a 25-way D-type connector (female) for the SA9604A

SK3 - a 4-pin connector for the SA9605A.

Only one of the output interfaces must be used at any one time to avoid conflict of signal levels on the opto-couplers.

**6. Jumper Configurations**

The jumper configurations required for the two devices types are shown below:

JUMPER POSITION	SA9604A	SA9605A	NOTES
JP1 1 - 2	Insert	Insert	Note 1
JP2 1 - 2	Insert	Insert	
JP3 1 - 2	Insert	Insert	
JP4 1 - 2 2 - 3 3 - 4	Remove Remove Insert (SCK)	Insert (FOUT1) Insert (FOUT2) Remove	Note 2
JP5 1 - 2 2 - 3	Remove Insert (CS)	Insert (PGM1=1) Remove (PGM1=0)	Note 3
JP6 1 - 2 2 - 3	Remove Insert (DI)	Insert (PGM0=1) Remove (PGM0=0)	Note 3
JP7 1 - 2	Remove	Insert	

Note 1: The removal of the link on the current sensor input must only be performed during calibration.

Note 2: Only one of the two output pulse signals on the SA9605A may be selected at any one time using this module. In a users application both of these signals may be used.

Note 3: The SA9605A I.C. has on-board pull-down resistors, pull-up connection to VDD is, therefore, the only connection which must be catered for.

## 7. Circuit Description

The module is supplied from an on-board DC supply derived from the incoming three phases.

The Application Circuit (Figure 2) details the components required for a three phase power metering module. Terminated current transformers are used as current sensors.

The most important external components are:

Terminated current sensors (current transformers) are connected to the current sensor inputs of the devices through current setting resistors (R8...R13).

The resistor values should be selected for an input current of  $16\mu A_{RMS}$  into the integrated circuit current sensor inputs at the rated line current.

The values of these resistors are calculated as follows:

Phase 1:

$$R_8 = R_9 = (I_{L1}/16\mu A_{RMS}) \times R_{17}/2$$

Phase 2:

$$R_{10} = R_{11} = (I_{L2}/16\mu A_{RMS}) \times R_{18}/2$$

Phase 3:

$$R_{12} = R_{13} = (I_{L3}/16\mu A_{RMS}) \times R_{19}/2$$

Where  $I_{LX}$  = Secondary CT current at rated conditions.  
 $R_{17}$ ,  $R_{18}$  and  $R_{19}$  = Termination resistors of the three current transformers.

$R_{1A}$ ,  $R_{1B}$ ,  $R_4$  and  $R_{14}$  set the current for the phase 1 voltage sense input.  $R_{2A} + R_{2B}$ ,  $R_5$  and  $R_{15}$  set the current Phase 2 and  $R_{3A} + R_{3B}$ ,  $R_6$  and  $R_{16}$  set the current for Phase 3. The values should be selected so that the input current into the voltage sense input (virtual ground) is set to  $14\mu A_{RMS}$  at nominal line voltage. Capacitors C1, C2 and C3 are for decoupling and phase compensation.

Resistors  $R_{7A} + R_{7B}$  and trimpot  $T_7$  defines all on-chip bias currents.  $R_7$  is made up of two resistors which can be connected in parallel using JP7 to allow conversion of the module between the SA9604A and SA9605A devices.

The SA9604A uses a reference current of  $25\mu A \pm 10\%$  and the SA9605A reference current is  $50\mu A \pm 10\%$ . Inserting the jumper will connect  $R_{7A}$  and  $R_{7B}$  in parallel, thereby doubling the reference current to an appropriate level.  $T_7$  may be varied for calibration purposes.

XTAL is a colour burst TV crystal ( $f = 3.5795$  MHz) for the oscillator. The oscillator frequency is divided down to 1.7897 MHz on-chip to supply the digital circuitry and the A/D converters.

**8. Demonstration Software**

Software to demonstrate the capabilities of the SA9604A is provided with the module. This software is supplied on a 3½" disk and will operate under Windows 95 or Windows 3.1 environment.

**Figure 1: Module layout**

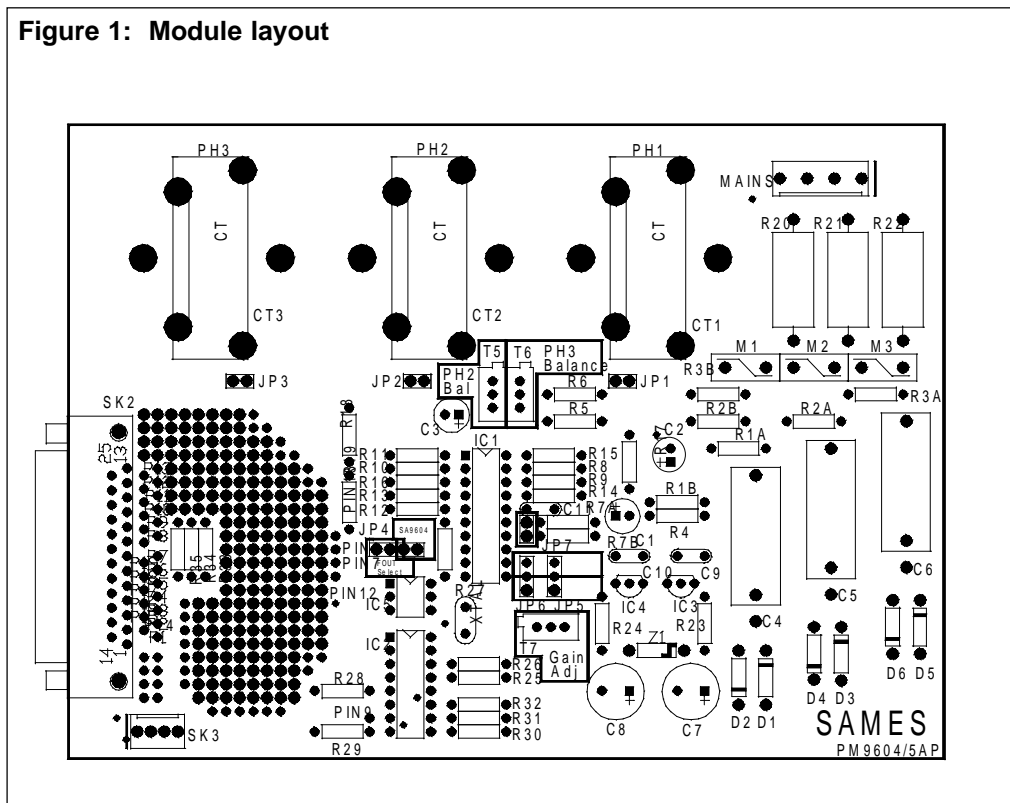

**Note:**

The pins of the voltage supply connector, called 'MAINS' have been incorrectly marked. The order of the pins should read: N (Neutral), Ph 3, Ph 2, Ph 1.

The printed circuit board markings of the Ph 1 and Ph 3 pins have been swapped.

Figure 2: Application Schematic

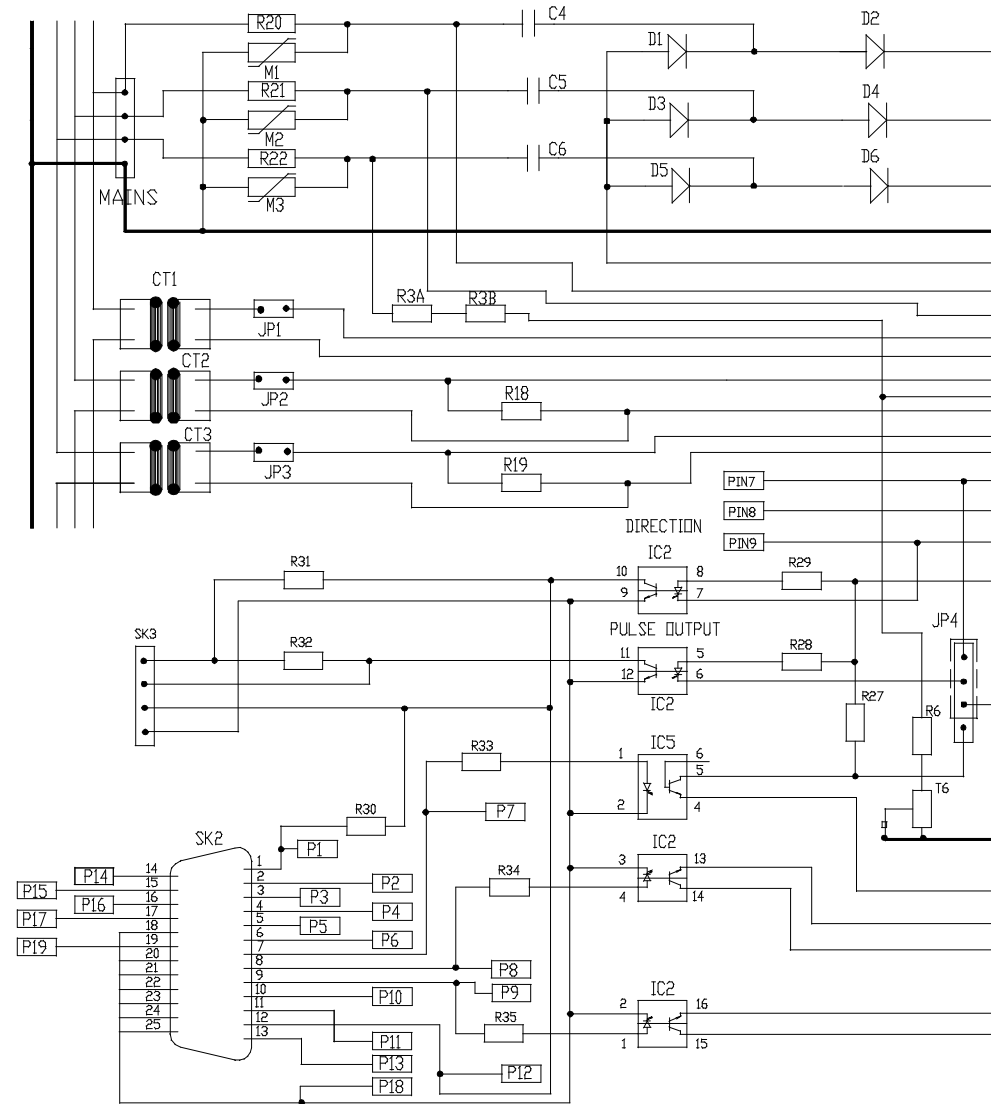

dr-01320



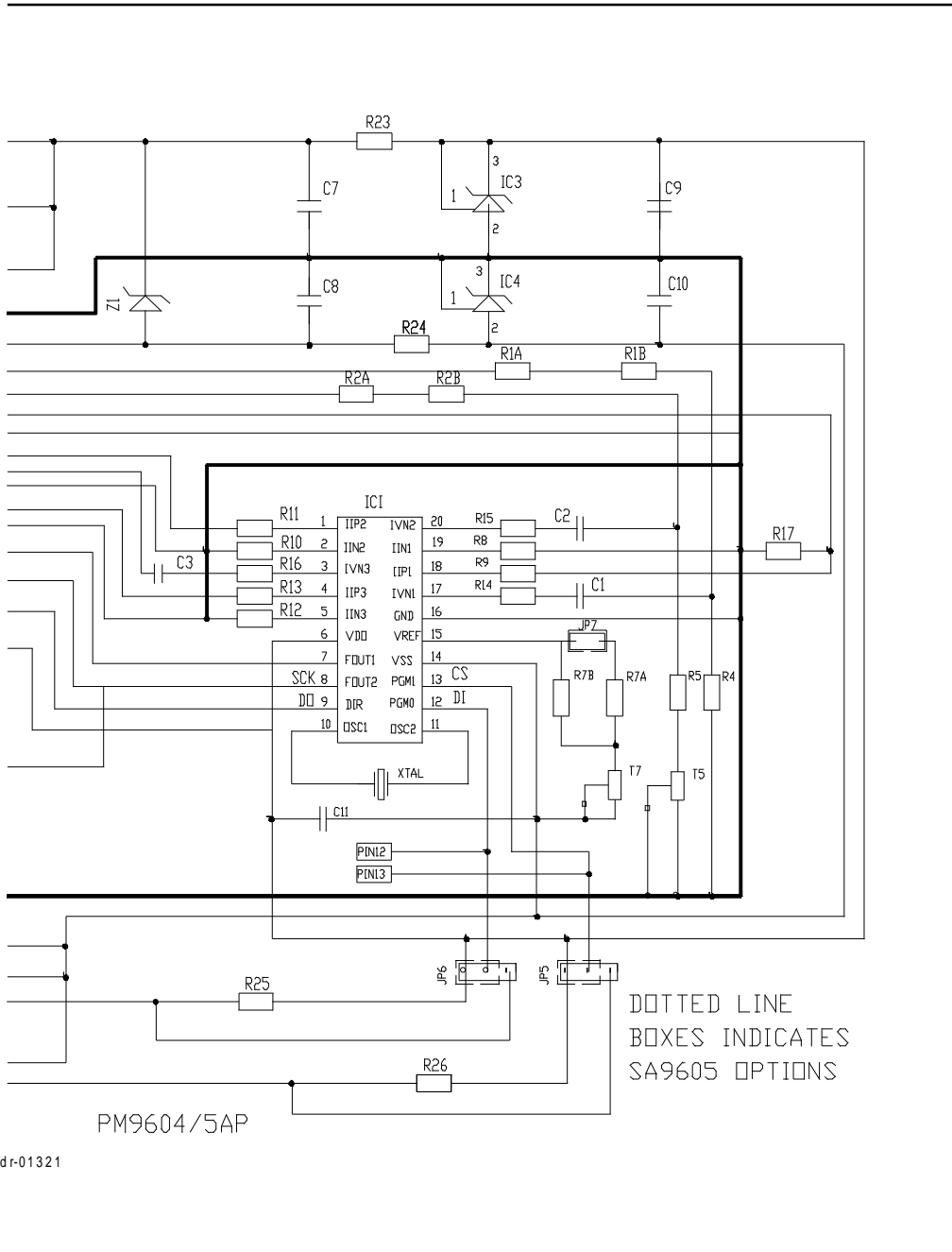

DOTTED LINE  
BOXES INDICATES  
SA9605 OPTIONS

PM9604/5AP

dr-01321

**PM9604/5AP****Parts List for Application Circuit: Figure 2**

Item	Symbol	Description	Detail
1	IC-1	SA9604AP / SA9605AP	DIP-20
2	XTAL	Crystal, 3.5795 MHz	TV Crystal
3	R1A	Resistor, 1%, ¼W, Metal	Note 4
4	R1B	Resistor, 1%, ¼W, Metal	Note 4
5	R2A	Resistor, 1%, ¼W, Metal	Note 4
6	R2B	Resistor, 1%, ¼W, Metal	Note 4
7	R3A	Resistor, 1%, ¼W, Metal	Note 4
8	R3B	Resistor, 1%, ¼W, Metal	Note 4
9	R4	Resistor, 24k, 1%, ¼W, Metal	
10	R5	Resistor, 22k, 1%, ¼W, Metal	
11	R6	Resistor, 22k, 1%, ¼W, Metal	
12	R7A	Resistor, 44k, 1%, ¼W, Metal	
13	R7B	Resistor, 44k, 1%, ¼W, Metal	
14	R8	Resistor, 2.7k, 1%, ¼W, Metal	Note 1
15	R9	Resistor, 2.7k, 1%, ¼W, Metal	Note 1
16	R10	Resistor, 2.7k, 1%, ¼W, Metal	Note 1
17	R11	Resistor, 2.7k, 1%, ¼W, Metal	Note 1
18	R12	Resistor, 2.7k, 1%, ¼W, Metal	Note 1
19	R13	Resistor, 2.7k, 1%, ¼W, Metal	Note 1
20	R14	Resistor, 1M, 1%, ¼W, Metal	
21	R15	Resistor, 1M, 1%, ¼W, Metal	
22	R16	Resistor, 1M, 1%, ¼W, Metal	
23	R17	Resistor, 2.7Ω, 1%, ¼W, Metal	Note 1
24	R18	Resistor, 2.7Ω, 1%, ¼W, Metal	Note 1
25	R19	Resistor, 2.7Ω, 1%, ¼W, Metal	Note 1
27	T5	Potentiometer, 4.7k	Multi turn. Note 5
28	T6	Potentiometer, 4.7k	Multi turn. Note 5
29	T7	Potentiometer, 10k	Multi turn. Note 5
30	C1	Capacitor, electrolytic, 1μF, 16V	Note 2
31	C2	Capacitor, electrolytic, 1μF, 16V	Note 2
32	C3	Capacitor, electrolytic, 1μF, 16V	Note 2
33	R20	Resistor, 470Ω, 2W	
34	R21	Resistor, 470Ω, 2W	
35	R22	Resistor, 470Ω, 2W	
36	R23	Resistor, 680Ω, 1% ¼W, Metal	
37	R24	Resistor, 680Ω, 1% ¼W, Metal	
38	R25	Resistor, 2.4k, 1% ¼W, Metal	
39	R26	Resistor, 2.4k, 1% ¼W, Metal	
40	R27	Resistor, 2.4k, 1% ¼W, Metal	



## Parts List for Application Circuit: Figure 2 (Continued)

Item	Symbol	Description	Detail
41	R28	Resistor, 820R, 1% ¼W, Metal	
42	R29	Resistor, 820R, 1% ¼W, Metal	
43	R31	Resistor, 47k, 1% ¼W, Metal	
44	R32	Resistor, 47k, 1% ¼W, Metal	
44	R33	Resistor, 680R, 1% ¼W, Metal	
45	R34	Resistor, 680R, 1% ¼W, Metal	
46	R35	Resistor, 680R, 1% ¼W, Metal	
47	C4	Capacitor	Note 4
48	C5	Capacitor	Note 4
49	C6	Capacitor	Note 4
50	C7	Capacitor, 200µF, 35V	
51	C8	Capacitor, 200µF, 35V	
52	C9	Capacitor, Tantalum, 10µF	
53	C10	Capacitor, Tantalum, 10µF	
54	C11	Capacitor, Ceramic 820nF	Note 3
55	XTAL	Crystal, 3.5795MHz	TV Crystal
56	D1	Diode, 1N4002	
57	D2	Diode, 1N4002	
58	D3	Diode, 1N4002	
59	D4	Diode, 1N4002	
60	D5	Diode, 1N4002	
61	D6	Diode, 1N4002	
62	Z1	Diode, Zener, 22V	
63	IC3	TL 431C, Voltage Reference	
64	IC4	TL 431C, Voltage Reference	
65	IC2	Quad Opto Coupler, ILQ73	
66	IC5	Opto Coupler, 4N35	

Note 1: Resistor ( $R_8$ ,  $R_9$ ,  $R_{10}$ ,  $R_{11}$ ,  $R_{12}$  and  $R_{13}$ ) values are dependant upon the selected values of the current transformer termination resistors  $R_{17}$ ,  $R_{18}$  and  $R_{19}$ .

Note 2: Capacitor values may be selected to compensate for phase errors caused by the current transformers

Note 3: Capacitor (C11) to be positioned as close to Supply Pins ( $V_{DD}$  &  $V_{SS}$ ) of IC-1, as possible.

Note 4: See the table below detailing the component values for the selected voltage standard.

Note 5: Trimpots required for calibration.

**PM9604/5AP**

---

Item	Symbol	Description		Detail
		PM9604/5APE 230V	PM9604/5APA 115V	
3	R1A	200k $\Omega$	120k $\Omega$	
4	R1B	180k $\Omega$	82k $\Omega$	
5	R2A	200k $\Omega$	120k $\Omega$	
6	R2B	180k $\Omega$	82k $\Omega$	
7	R3A	200k $\Omega$	120k $\Omega$	
8	R3B	180k $\Omega$	82k $\Omega$	
47	C4	470nF	1 $\mu$ F	
48	C5	470nF	1 $\mu$ F	
49	C6	470nF	1 $\mu$ F	

**ORDERING INFORMATION**

Part Number	Description
PM9604/5APA	3 X 115V, 3 X 80A Module
PM9604/5APE	3 X 230V, 3 X 80A Module



NOTE:



**Disclaimer:** The information contained in this document is confidential and proprietary to South African Micro-Electronic Systems (Pty) Ltd ("SAMES") and may not be copied or disclosed to a third party, in whole or in part, without the express written consent of SAMES. The information contained herein is current as of the date of publication; however, delivery of this document shall not under any circumstances create any implication that the information contained herein is correct as of any time subsequent to such date. SAMES does not undertake to inform any recipient of this document of any changes in the information contained herein, and SAMES expressly reserves the right to make changes in such information, without notification, even if such changes would render information contained herein inaccurate or incomplete. SAMES makes no representation or warranty that any circuit designed by reference to the information contained herein, will function without errors and as intended by the designer.

Any sales or technical questions may be posted to our e-mail address below:  
[energy@sames.co.za](mailto:energy@sames.co.za)

For the latest updates on datasheets, please visit our web site:  
<http://www.sames.co.za>

**South African Micro-Electronic Systems (Pty) Ltd**

P O Box 15888,	33 Eland Street,
Lynn East,	Koedoespoort Industrial Area,
0039	Pretoria,
Republic of South Africa,	Republic of South Africa

Tel: 012 333-6021  
Fax: 012 333-8071

Tel: Int +27 12 333-6021  
Fax: Int +27 12 333-8071

